

GAS ENGINE-GENERATOR SET

30-GC6NLT1

30 ekW / 60 Hz / Standby
208 - 600V



SYSTEM RATINGS

Standby

Voltage (L-L)	240V**	240V**	208V**	240V**	480V**	600V**
Phase	1	1	3	3	3	3
PF	1.0	1.0	0.8	0.8	0.8	0.8
Hz	60	60	60	60	60	60
Natural Gas						
Ratings: Amps	117	117	104	90	45	36
Natural Gas						
Ratings: kW/kVA	28/28	28/28	30/37.5	30/37.5	30/37.5	30/37.5
LP Gas						
Ratings: Amps	125	125	104	90	45	36
LP Gas						
Ratings: kW/kVA	30/30	30/30	30/37.5	30/37.5	30/37.5	30/37.5
skVA@30%						
Voltage Dip	70	63	70	70	90	122
Generator Model*	284CSL1542	283CSL1517	284CSL1508	284CSL1508	284CSL1508	284PSL1752
Temp Rise	130°C/27°C	125°C/40°C	130°C/27°C	130°C/27°C	130°C/27°C	125°C/40°C
Connection	12 LEAD ZIG-ZAG	4 LEAD	12 LEAD LOW WYE	12 LEAD HI DELTA	12 LEAD HI WYE	4 LEAD WYE

* The Generator Model Number identified in the table is for standard C Series Configuration. Consult the factory for alternate configuration.

** UL2200 Offered

STANDARD FEATURES

- // Engine-Generator Set Tested to ISO 8528-5 for Transient Response
- // UL2200, CSA Listing Offered
- // Accepts Rated Load in One Step Per NFPA 110
- // All engine-generator sets are prototype and factory tested
- // MTU Onsite Energy is a single source supplier
- // Global Product Support
- // 2 Year Standard Warranty
- // Custom Design for Any Application
- // 3.0 L Engine
 - 3.0 Liter Displacement
 - 4-Cycle
- // Integral Vibration Isolators
- // Complete Range of Accessories
- // Permanent Magnet Generator (PMG) - Optional
 - Brushless, Rotating Field
 - 300% Short Circuit Capability
 - 2/3 Pitch Windings
- // Digital Control Panel(s)
 - UL Recognized, cULus, NFPA 110
 - Complete System Metering
 - LCD Display
- // Cooling System
 - Integral Set-Mounted
 - Engine Driven Fan

STANDARD EQUIPMENT

// Engine

Air Cleaner
 Oil Pump
 Full Flow Oil Filter
 Jacket Water Pump
 Thermostat
 Exhaust Manifold – Dry
 Blower Fan & Fan Drive
 Radiator – Unit Mounted
 Electric Starting Motor – 12V
 Governor – Electric Isochronous
 Base – Formed Steel
 SAE Flywheel & Bell Housing
 Charging Alternator – 12V
 Battery Box & Cables
 Flexible Fuel Connectors
 Flexible Exhaust Connection
 EPA Certified Engine

// Generator

NEMA MG1, IEEE and ANSI standards compliance for temperature rise and motor starting
 Sustained short circuit current of up to 300% of the rated current for up to 10 seconds
 Self-Ventilated and Drip-Proof
 Superior Voltage Waveform
 Digital, Solid State, Volts-per-Hertz Regulator
 No Load to Full Load Regulation
 Brushless Alternator with Brushless Pilot Exciter
 4 Pole, Rotating Field
 130°C Standby Temperature Rise
 1 Bearing, Sealed
 Flexible Coupling
 Full Amortisseur Windings
 125% Rotor Balancing
 3-Phase Voltage Sensing
 ±.25% Voltage Regulation
 100% of Rated Load – One Step
 3% Maximum Harmonic Content

// Digital Control Panel(s)

Digital Metering
 Engine Parameters
 Generator Protection Functions
 Engine Protection
 SAE J1939 Engine ECU Communications
 Windows-Based Software
 Multilingual Capability
 Remote Communications to our RDP-110 Remote Annunciator
 16 Programmable Contact Inputs
 7 Contact Outputs
 UL Recognized, cULus, CE Approved
 Event Recording
 IP 54 Front Panel Rating with Integrated Gasket
 NFPA110 Level Compatible

APPLICATION DATA

// Engine

Manufacturer	GM
Model	3.0L
Type	4-Cycle
Arrangement	4-Inline
Displacement: Cu In (lit)	181 (3)
Bore: in (cm)	4 (10.2)
Stroke: in (cm)	3.6 (9.1)
Compression Ratio	9.25:1
Rated RPM	1,800
Engine Governor	Bosch
Max Power: Standby: bhp (kWm)	51.5 (38.4)
Speed Regulation	±1%
Frequency	60 Hz
Air Cleaner	Dry

// Liquid Capacity (Lubrication)

Total Oil System: gal (lit)	1.3 (4.9)
Engine Jacket Water Capacity: gal (lit)	1 (3.8)
System Coolant Capacity: gal (lit)	3.9 (14.8)

// Electrical

Electric Volts DC	12
Cold Cranking Amps Under 0°F (-17.8°C)	600

// Fuel Inlet

Fuel Supply Connection Size	3/4" NPT
Fuel Supply Pressure: in. H ₂ O (mm H ₂ O)	7-11 (178-279)

// Fuel Consumption (NG-1000 BTU/ft³ / LP-2500 BTU/ft³)

	NG	LPG
At 100% of Power Rating: ft ³ /hr (m ³ /hr)	361 (10.2)	159 (4.5)
At 75% of Power Rating: ft ³ /hr (m ³ /hr)	270 (7.7)	120 (3.4)
At 50% of Power Rating: ft ³ /hr (m ³ /hr)	189 (5.4)	84 (2.4)

// Cooling - Radiator System

Ambient Capacity of Radiator: °F (°C)	122 (50)
Max. Restriction of Cooling Air, Intake, and Discharge Side of Rad.: in. H ₂ O (kPa)	0.5 (0.12)
Water Pump Capacity: gpm (lit/min)	17 (64.4)
Heat Rejection to Coolant: BTUM (kW)	1,436 (25.3)
Heat Radiated to Ambient: BTUM (kW)	886 (15.6)

// Air Requirements

Aspirating: *SCFM (m ³ /min)	94.3 (2.7)
Air Flow Required for Rad. Cooled Unit: *SCFM (m ³ /min)	2,882.39 (81.6)
Air Flow Required for Heat Exchanger/Remote Rad. based on 25°F Rise *SCFM: (m ³ /min)	1,998 (56.6)

* Air density = 0.0739 lbm/ft³ (1.184 kg/m³)

// Exhaust System

Gas Temp. (Stack): °F (°C)	1,300 (704.4)
Gas Volume at Stack Temp: CFM (m ³ /min)	304.53 (8.6)
Maximum Allowable Back Pressure: in. H ₂ O (kPa)	40 (10)

WEIGHTS AND DIMENSIONS

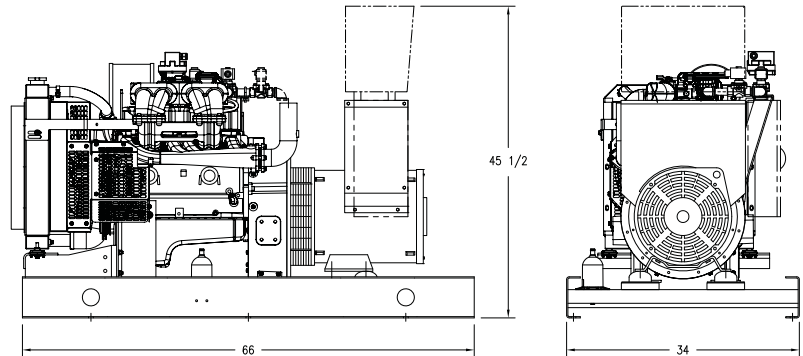

Drawing above for illustration purposes only, based on standard open power 480 volt generator. Lengths may vary with other voltages. Do not use for installation design.

System	Dimensions (L x W x H)	Weight (dry)
OPU	66 x 34 x 45.5 in (1,676 x 864 x 1,156 mm)	1,010 lb (458 kg)

Weights and dimensions are based on open power units and are estimates only. Consult the factory for accurate weights and dimensions for your specific generator set.

SOUND DATA

Unit Type	Standby Full Load	Standby No Load
OPU (dBA)	C/F	C/F
WPE - No Sound Attenuation (dBA)	C/F	C/F
CQE (dBA)	C/F	C/F

Measurements for sound data are taken at 23 ft (7m).

EMISSIONS DATA

Fuel Type	THC + NO _x	CO
Natural Gas	9.67	39.49
Liquid Propane	13.31	43.76

All units are in g/hp-hr.
Engine meets EPA 40 CFR Part 60/90 specifications.

RATING DEFINITIONS AND CONDITIONS

- // Ambient capability factor at 984 ft (300 m). Consult your local MTU Onsite Energy Power Generation Distributor for other altitudes.
- // Standby ratings apply to installations served by a reliable utility source. The standby rating is applicable to varying loads for the duration of a power outage. No overload capability for this rating. Ratings are in accordance with ISO-3046/1, BS 5514, AS 2789, and DIN 6271.
- // Deration Factor:
 - Altitude:** 3% per 1,000 ft (305 m) above 328 ft (100 m).
 - Temperature:** 1% per 10°F (5.5°C) above 77°F (25°C).

Materials and specifications subject to change without notice.