

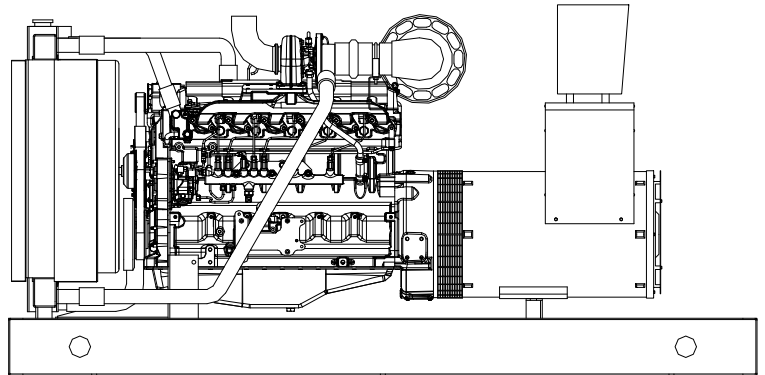

125-JC6DT3

125 ekW 60 Hz Standby
115 ekW 60 Hz Prime
208 - 600V



- EPA Tier 3 Certified
- Generator Set Tested to ISO 8528-5 for Transient Response
- UL2200, CSA Listing Offered
- Accepts Rated Load in One Step Per NFPA 110, Level 1
- All gen-sets are prototype and factory tested
- MTU DD is a single source supplier
- Global Product Support
- 2 Year Standard Warranty
- Complete Range of Accessories
- Custom Design for any Application

- 6068HF285 Diesel Engine
 - 6.8 Liter Displacement
 - 4-Cycle
- Permanent Magnet Generator (PMG) - Optional
 - Brushless, Rotating Field
 - 300% Short Circuit Capability
 - 2/3 Pitch Windings
- Digital Control Panel(s)
 - UL Recognized, **UL US**, NFPA 110
 - Complete System Metering
 - LCD Display
- Cooling System
 - Integral Set-mounted
 - Engine Driven Fan

GEN-SET RATINGS

Standby

| Voltage (L-L) | Phase | PF | Hz | kW | kVA | AMPS | skVA @ 30% voltage dip | Generator Model* | Temp Rise | Connection |
|---------------|-------|-----|----|-----|--------|------|------------------------|------------------|------------|------------------|
| 240v** | 1 | 1.0 | 60 | 125 | 125 | 521 | 136 | 431CSL6204 | 130°C/27°C | 12 LEAD ZIG-ZAG |
| 240v** | 1 | 1.0 | 60 | 125 | 125 | 521 | 195 | 431PSL6224 | 130°C/27°C | 4 LEAD |
| 208v** | 3 | 0.8 | 60 | 125 | 156.25 | 434 | 250 | 363CSL1607 | 130°C/27°C | 12 LEAD LOW WYE |
| 240v** | 3 | 0.8 | 60 | 125 | 156.25 | 376 | 250 | 363CSL1607 | 130°C/27°C | 12 LEAD HI DELTA |
| 480v** | 3 | 0.8 | 60 | 125 | 156.25 | 188 | 330 | 363CSL1607 | 130°C/27°C | 12 LEAD HI WYE |
| 600v** | 3 | 0.8 | 60 | 125 | 156.25 | 150 | 335 | 363PSL1675 | 125°C/40°C | 4 LEAD WYE |

Prime

| Voltage (L-L) | Phase | PF | Hz | kW | kVA | AMPS | skVA @ 30% voltage dip | Generator Model* | Temp Rise | Connection |
|---------------|-------|-----|----|-----|--------|------|------------------------|------------------|------------|------------------|
| 240v | 1 | 1.0 | 60 | 115 | 115 | 479 | 136 | 431PSL6204 | 105°C/40°C | 12 LEAD ZIG-ZAG |
| 240v | 1 | 1.0 | 60 | 115 | 115 | 479 | 195 | 431PSL6224 | 105°C/40°C | 4 LEAD |
| 208v | 3 | 0.8 | 60 | 115 | 138 | 399 | 250 | 363PSL1607 | 105°C/40°C | 12 LEAD LOW WYE |
| 240v | 3 | 0.8 | 60 | 115 | 143.75 | 346 | 250 | 363PSL1607 | 105°C/40°C | 12 LEAD HI DELTA |
| 480v | 3 | 0.8 | 60 | 115 | 143.75 | 173 | 330 | 363PSL1607 | 105°C/40°C | 12 LEAD HI WYE |
| 600v | 3 | 0.8 | 60 | 115 | 143.75 | 138 | 335 | 363PSL1675 | 105°C/40°C | 4 LEAD WYE |

* The Generator Model Number identified in the table is for standard C Series Configuration. Consult the factory for alternate configuration.

** UL2200 Offered



STANDARD EQUIPMENT

ENGINE

- Air Cleaners
- Oil Pump
- Full Flow Oil Filter
- Jacket Water Pump
- Thermostat
- Exhaust Manifold – dry
- Blower Fan & Fan Drive
- Radiator - Unit Mounted
- Electric Starting Motor - 12V
- Governor – Electric Isochronous
- Base - Formed Steel
- SAE Flywheel & Bell Housing
- Charging Alternator - 12V
- Battery Box & Cables
- Flexible Fuel Connectors
- Flexible Exhaust Connection
- EPA Certified Engine

DIGITAL CONTROL PANEL(S)

- Digital Metering
- Engine Parameters
- Generator Protection Functions
- Engine Protection
- SAE J1939 Engine ECU Communications
- Windows-based Software
- Multilingual Capability
- Remote Communications to our RDP-110 Remote Annunciator
- 16 Programmable Contact Inputs
- 7 contact outputs
- UL Recognized,  **us**, CE approved
- Event Recording
- IP 54 Front Panel Rating with Integrated Gasket
- NFPA110 Level Compatible

GENERATOR

- NEMA MG1, IEEE and ANSI standards compliance for temperature rise and motor starting
- Sustained short circuit current of up to 300% of the rated current for up to 10 seconds
- Self Ventilated and Drip-proof
- Superior Voltage Waveform
- Digital, Solid State, Volts-per-hertz Regulator
- No Load to Full Load Regulation
- Brushless Alternator with Brushless Pilot Exciter
- 4 pole, Rotating Field
- 130°C Standby Temperature Rise
- 1 Bearing, Sealed
- Flexible Coupling
- Full Amortisseur Windings
- 125% Rotor Balancing
- 3-phase Voltage Sensing
- $\pm 1\%$ Voltage Regulation
- 100% of Rated Load - One Step
- 3% Maximum Harmonic Content



APPLICATION DATA

Engine

| | |
|--|--|
| Manufacturer: John Deere | Rated RPM: 1800 |
| Model: 6068HF285 | Engine Governor: JDEC |
| Type: 4-Cycle | Max Power: Standby: bhp (kWm) 237 (177) |
| Arrangement: 6-Inline | Prime: bhp (kWm) 216 (161) |
| Displacement: in. ³ (lit) 415 (6.8) | Speed Regulation: ±.25% |
| Bore: in. (cm) 4.19 (10.6) | Frequency: 60 Hz |
| Stroke: in. (cm) 5.0 (12.7) | Air Cleaner: Dry |
| Compression Ratio: 19.0:1 | |

Liquid Capacity (Lubrication)

| |
|---|
| Total oil system: gal (lit)..... 5.28 (20.0) |
| Engine Jacket water capacity: gal (lit) 3.25 (12.3) |
| System Coolant capacity: gal (lit) 6.0 (22.7) |

Electrical

| |
|---|
| Electric volts DC: 12 |
| Cold cranking Amps under 0°F (-17.8°C): 800 |

Fuel System

| |
|---|
| Fuel Supply Connection Size:..... 3/8" NPT |
| Fuel Return Connection Size: 3/8" NPT |
| Maximum Fuel Lift: ft (m) 10 (3) |
| Recommended Fuel: Diesel #2 |
| Total Fuel Flow: gal/hr (lit/hr) 28.3 (107.2) |

Fuel Consumption

| | Standby | Prime |
|--|---------|-------|
| 100% Power Rating: gal/hr (lit/hr) 8.9 (33.7) ... 8.0 (30.3) | | |
| 75% Power Rating: gal/hr (lit/hr) 6.9 (26.1) ... 6.2 (23.5) | | |
| 50% Power Rating: gal/hr (lit/hr) 5.0 (18.9) ... 4.5 (17.0) | | |

Cooling - Radiator System

| | Standby | Prime |
|---|---------|-------|
| Ambient Capacity of Radiator: °F (°C)..... 122 (50) 122 (50) | | |
| Maximum Allowable Static Pressure on Radiator Exhaust: in. H ₂ O (kPa) 0.5 (0.12) 0.5 (0.12) | | |
| Water Pump Capacity: gpm (lit/min) 48 (180) 48 (180) | | |
| Heat Rejection to Coolant: BTUM (kW) 5,324 (93.5) 4,792 (84.3) | | |
| Heat Rejection to Air to Air: BTUM (kW) 1,821 (32)..... 1,702 (30) | | |
| Heat Radiated to Ambient: BTUM (kW) 871 (15.3)..... 762 (13.4) | | |

Air Requirements

| | Standby | Prime |
|---|---------|-------|
| Aspirating: CFM (m ³ min)..... 480 (13.6)..... 452 (12.8) | | |
| Air Flow Required for Radiator Cooled Unit: CFM (m ³ min) 9,216 (261) 9,216 (261) | | |
| Air Flow Required for Heat Exchanger/ Remote Radiator based on 25°F Rise: CFM (m ³ min)..... 1,935 (54.8) 1,694 (47.9) | | |

Exhaust System

| | Standby | Prime |
|--|---------|-------|
| Gas Temp.(Stack): °F (°C) 941 (505) 916 (491) | | |
| Gas Volume at Stack Temp: CFM (m ³ min) 1,201 (34.0) .. 1,165 (33.0) | | |
| Maximum Allowable Back Pressure: in. H ₂ O (kPa): 30 (7.5) 30 (7.5) | | |



125 kW Diesel Gen-Set

EMISSIONS DATA

| <u>NOx + NMHC</u> | <u>CO</u> | <u>PM</u> |
|-------------------|--------------|--------------|
| 2.65 g/hp-hr | 0.98 g/hp-hr | 0.13 g/hp-hr |

All units are in g/hp-hr and are EPA D2 cycle values.

Emission levels of the engine may vary as a function of ambient temperature, barometric pressure, humidity, fuel type and quality, installation parameters, measuring instrumentation, etc. The data provided are laboratory results from one engine representing this rating. The data was obtained under controlled environmental conditions with calibrated instrumentation traceable to the United States National Bureau of Standards and in compliance with US EPA regulations found within 40 CFR Part 89. The weighted cycle value from each engine is guaranteed to be below the US EPA Standards at the US EPA defined conditions.

SOUND DATA

| | <u>Standby Full Load</u> | <u>Standby No Load</u> | <u>Prime Full Load</u> | <u>Prime No Load</u> |
|---|--------------------------|------------------------|------------------------|----------------------|
| 23 ft (7m) OPU w/ critical grade muffler: (dBA) | 91.5 | 84 | 90 | 84 |
| 23 ft (7m) Sound Attenuated Enclosure: (dBA) | 83.5 | 76 | 82 | 76 |

RATING DEFINITIONS and CONDITIONS

- Ambient capability factor at 300m (984ft). Consult your local DDC/MTU Power Generation Distributor for other altitudes.
- Standby ratings apply to installations served by a reliable utility source. The standby rating is applicable to varying loads for the duration of a power outage. No overload capability for this rating. Ratings are in accordance with ISO-3046/1, BS 5514, AS 2789, and DIN 6271.
- Prime power ratings apply to installations where utility power is unavailable or unreliable. At varying load, the number of generator set operating hours is unlimited. A 10% overload capacity is available for one hour in twelve. Ratings are in accordance with ISO-8528/1, overload power in accordance with ISO-3046/1, BS 5514, AS 2789, and DIN 6271. For limited running time and base load ratings, consult the factory.
- Deration Factors:
 - Altitude: 0.5% per 1,000 ft (305m) above 5,000 ft (1,524m) and 4% per 1,000 ft (305m) above 10,000 ft (3,048m).
 - Temperature: 0.5% per 10°F (5.5°C) above 77°F (25°C).

Weights & Dimensions

| | |
|------------------------|---------------|
| Length: in. (cm) | 105 (267) |
| Width: in. (cm) | 36 (91) |
| Height: in. (cm) | 52 (132) |
| Weight (dry): lb. (kg) | 2,821 (1,280) |

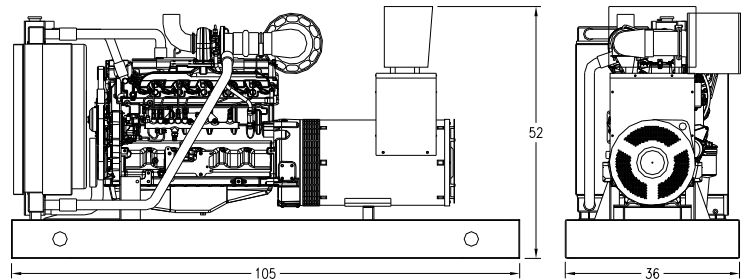

Drawing above for illustration purposes only, based on standard open power 480 volt generator. Lengths may vary with other voltages.
*Do Not Use for Installation Design

DISTRIBUTED BY:

Materials and specifications subject to change without notice.
© MTU DD Power Generation. A Tognum Group Company.
100 Power Drive, Mankato, MN 56001
Phone: 800-325-5450
www.mtuddpowergeneration.com