

DIESEL ENGINE-GENERATOR SET

1000-XC6DT2

1000 ekW / 60 Hz / Standby
 900 ekW / 60 Hz / Prime
 208 - 4160V



SYSTEM RATINGS

Standby

Voltage (L-L)	208V**	240V**	480V**	600V**	4160V
Phase	3	3	3	3	3
PF	0.8	0.8	0.8	0.8	0.8
Hz	60	60	60	60	60
kW	1000	1000	1000	1000	1000
kVA	1250	1250	1250	1250	1250
AMPS	3470	3007	1504	1203	173
skVA@30%					
Voltage Dip	2600	2600	3200	1550	2600
Generator Model*	741RSL4045	741RSL4045	575RSL4044	741RSS4282	742FSM4364
Temp Rise	130°C/27°C	130°C/27°C	130°C/27°C	125°C/40°C	130°C/27°C
Connection	12 LEAD LOW WYE	12 LEAD HI DELTA	4 BAR WYE	4 LEAD WYE	6 LEAD WYE

Prime

Voltage (L-L)	208V	240V	480V	600V	4160V
Phase	3	3	3	3	3
PF	0.8	0.8	0.8	0.8	0.8
Hz	60	60	60	60	60
kW	900	900	900	900	900
kVA	1125	1125	1125	1125	1125
AMPS	3123	2706	1353	1083	156
skVA@30%					
Voltage Dip	2600	2600	3200	1550	2600
Generator Model*	741RSL4045	741RSL4045	575RSL4044	741RSS4282	742FSM4364
Temp Rise	105°C/40°C	105°C/40°C	105°C/40°C	105°C/40°C	105°C/40°C
Connection	12 LEAD LOW WYE	12 LEAD HI DELTA	4 BAR WYE	4 LEAD WYE	6 LEAD WYE

* The Generator Model Number identified in the table is for standard C Series Configuration. Consult the factory for alternate configuration.

** UL2200 Offered

STANDARD FEATURES

- // EPA Tier 2 Certified
- // Engine-Generator Set Tested to ISO 8528-5 for Transient Response
- // UL2200, CSA Listing Offered
- // Accepts Rated Load in One Step Per NFPA 110
- // All engine-generator sets are prototype and factory tested
- // MTU Onsite Energy is a single source supplier
- // Global Product Support
- // 2 Year Standard Warranty
- // Custom Design for Any Application
- // 16V 2000 G85 Diesel Engine
 - 31.8 Liter Displacement
 - Electronic Unit Pump Injection
 - 4-Cycle
- // Complete Range of Accessories
- // Permanent Magnet Generator (PMG)
 - Brushless, Rotating Field
 - 300% Short Circuit Capability
 - 2/3 Pitch Windings
- // Digital Control Panel(s)
 - UL Recognized,  us, NFPA 110
 - Complete System Metering
 - LCD Display
- // Cooling System
 - Integral Set-Mounted
 - Engine Driven Fan

STANDARD EQUIPMENT

// Engine

Air Cleaners

Oil Pump

Full Flow Oil Filter

Jacket Water Pump

Inter Cooler Water Pump

Closed Crankcase Vent

Thermostats

Exhaust Manifold - Dry

Blower Fan & Fan Drive

Radiator - Unit Mounted

Electric Starting Motor - 24V

Governor - Electric Isochronous

Base - Structural Steel

SAE Flywheel & Bell Housing

Charging Alternator - 24V

Battery Box & Cables

Flexible Fuel Connectors

Flexible Exhaust Connection

EPA Certified Engine

// Generator

NEMA MG1, IEEE and ANSI standards compliance for temperature rise and motor starting

Sustained short circuit current of up to 300% of the rated current for up to 10 seconds

Self-Ventilated and Drip-Proof

Superior Voltage Waveform

Digital, Solid State, Volts-per-Hertz Regulator

No Load to Full Load Regulation

Brushless Alternator with Brushless Pilot Exciter

4 Pole, Rotating Field

130°C Standby Temperature Rise

1 Bearing, Sealed

Flexible Coupling

Full Amortisseur Windings

125% Rotor Balancing

3-Phase Voltage Sensing

±.25% Voltage Regulation

100% of Rated Load - One Step

3% Maximum Harmonic Content

// Digital Control Panel(s)

Digital Metering

Engine Parameters

Generator Protection Functions

Engine Protection

SAE J1939 Engine ECU Communications

Windows-Based Software

Multilingual Capability

Remote Communications to our RDP-110 Remote Annunciator

16 Programmable Contact Inputs

7 Contact Outputs

UL Recognized,  us, CE Approved

Event Recording

IP 54 Front Panel Rating with Integrated Gasket

NFPA110 Level Compatible

APPLICATION DATA

// Engine

Manufacturer	MTU
Model	16V 2000 G85TB
Type	4-Cycle
Arrangement	16-V
Displacement: Cu In (lit)	1,943 (31.8)
Bore: in (cm)	5.1 (13)
Stroke: in (cm)	5.9 (15)
Compression Ratio	16:1
Rated RPM	1,800
Engine Governor	ADEC
Max Power: Standby: bhp (kWm)	1,495 (1,115)
Max Power: Prime: bhp (kWm)	1,354 (1,010)
Regulation	±.25%
Frequency	60 Hz
Air Cleaner	Dry

// Liquid Capacity (Lubrication)

Total Oil System: gal (lit)	26.9 (102)
Engine Jacket Water Capacity: gal (lit)	34.3 (130)
After Cooler Water Capacity: gal (lit)	5.3 (20)
System Coolant Capacity: gal (lit)	110 (415)

// Electrical

Electric Volts DC	24
Cold Cranking Amps Under 0°F (-17.8°C)	1,900

// Fuel System

Fuel Supply Connection Size	3/4" NPT
Fuel Return Connection Size	1/4" NPT
Maximum Fuel Lift: ft (m)	10 (3)
Recommended Fuel	Diesel #2
Total Fuel Flow: gal/hr (lit/hr)	127 (480.7)

// Fuel Consumption

	STANDBY	PRIME
At 100% of Power Rating: gal/hr (lit/hr)	71 (268.7)	64.3 (243.4)
At 75% of Power Rating: gal/hr (lit/hr)	53.8 (203.6)	49.2 (186.2)
At 50% of Power Rating: gal/hr (lit/hr)	36.7 (138.9)	33.4 (126.4)

// Cooling - Radiator System

	STANDBY	PRIME
Ambient Capacity of Radiator: °F (°C)	122 (50)	122 (50)
Max. Restriction of Cooling Air, Intake, and Discharge Side of Rad.: in. H ₂ O (kPa)	0.5 (0.12)	0.5 (0.12)
Water Pump Capacity: gpm (lit/min)	220 (833)	220 (833)
After Cooler Pump Capacity: gpm (lit/min)	68 (257)	68 (257)
Heat Rejection to Coolant: BTUM (kW)	22,747 (400)	20,188 (355)
Heat Rejection to After Cooler: BTUM (kW)	18,197 (320)	16,491 (290)
Heat Radiated to Ambient: BTUM (kW)	5,425 (95.4)	4,970 (87.4)

// Air Requirements

	STANDBY	PRIME
Aspirating: *SCFM (m ³ /min)	3,072 (87)	2,966 (84)
Air Flow Required for Rad. Cooled Unit: *SCFM (m ³ /min)	40,013 (1,133)	40,013 (1,133)
Air Flow Required for Heat Exchanger/Remote Rad. based on 25°F Rise: *SCFM (m ³ /min)	12,240 (346)	11,209 (317)

* Air density = 0.0739 lbm/ft³ (1.184 kg/m³)

// Exhaust System

	STANDBY	PRIME
Gas Temp. (Stack): °F (°C)	1,022 (550)	986 (530)
Gas Volume at Stack Temp: CFM (m ³ /min)	7,840 (222)	7,416 (210)
Maximum Allowable Back Pressure: in. H ₂ O (kPa)	34.1 (8.5)	34.1 (8.5)

WEIGHTS AND DIMENSIONS

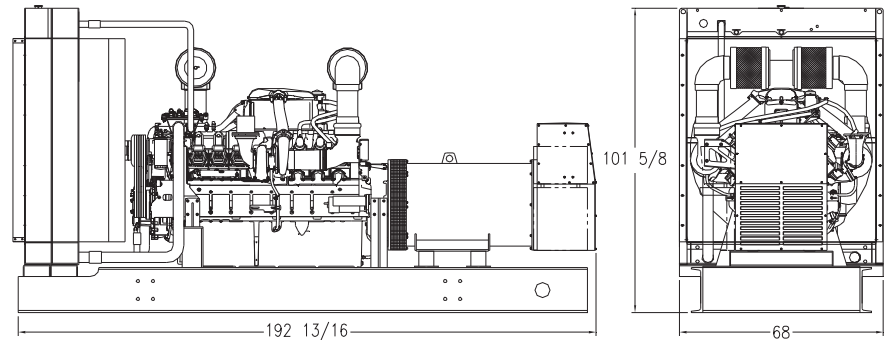

Drawing above for illustration purposes only, based on standard open power 480 volt generator. Lengths may vary with other voltages. Do not use for installation design.

System	Dimensions (LxWxH)	Weight (less tank)
OPU	197.4 x 76.5 x 102.5 in (5,010 x 1,940 x 2,600 mm)	17,807 lb (8,077 kg)

Weights and dimensions are based on open power units and are estimates only. Consult the factory for accurate weights and dimensions for your specific generator set.

SOUND DATA

Unit Type	Standby Full Load	Standby No Load	Prime Full Load	Prime No Load
OPU w/Critical Grade Muffler (dBA)	101.5	94	100	94
Sound Attenuated Enclosure (dBA)	93.5	86	92	86

Measurements for sound data are taken at 23 ft (7 m).

EMISSIONS DATA

NO _x + NMHC	CO	PM
5.5	1.44	0.131

All units are in g/hp-hr and are EPA D2 cycle values.

Emission levels of the engine may vary as a function of ambient temperature, barometric pressure, humidity, fuel type and quality, installation parameters, measuring instrumentation, etc. The data provided are laboratory results from one engine representing this rating. The data was obtained under controlled environmental conditions with calibrated instrumentation traceable to the United States National Bureau of Standards and in compliance with US EPA regulations found within 40 CFR Part 89. The weighted cycle value from each engine is guaranteed to be below the US EPA Standards at the US EPA defined conditions.

Materials and specifications subject to change without notice.

RATING DEFINITIONS AND CONDITIONS

- // Ambient capability factor at 984 ft (300 m). Consult your local MTU Onsite Energy Power Generation Distributor for other altitudes.
- // Standby ratings apply to installations served by a reliable utility source. The standby rating is applicable to varying loads for the duration of a power outage. No overload capability for this rating. Ratings are in accordance with ISO-3046/1, BS 5514, AS 2789, and DIN 6271.
- // Prime power ratings apply to installations where utility power is unavailable or unreliable. At varying load, the number of generator set operating hours is unlimited. A 10% overload capacity is available for one hour in twelve. Ratings are in accordance with ISO-8528/1, overload power in accordance with ISO-3046/1, BS 5514, AS 2789, and DIN 6271. For limited running time and base load ratings, consult the factory.
- // Deration Factor:
 - Altitude:** No derate with increased altitude at 77°F (25°C). Maximum altitude 5,906 ft (1,800 m).
 - Temperature:** No derate with increased temperature at 328 ft (100 m). Maximum ambient temperature 122°F (50°C).